



Job Name:

Catalog Number:

Type:

## SFAPL SERIES | SURFACE PANEL LIGHTS

### FEATURES

- Available in round and square forms with anodized satin nickel finish
- Available wattage range: 15 watts to 30 watts
- Low profile surface mounting luminaire with a modern look & high performance
- Edge-lit technology creates uniform distribution
- Low glare optic provides smooth diffused light

### CONSTRUCTION

- Super Slim Thin Die-cast aluminum frame for low to medium heights ceilings
- Constructed from durable aluminum that provides thermal cooling
- Aluminum backplate with integral snap tabs
- Can be mounted in retrofits, new construction, and remodel applications
- Available in round or square configurations

### ELECTRICAL

- Accommodates 120VAC at 50/60Hz
- Comes with UL listed control gear
- Power factor more than 0.9
- Total Harmonic Distortion less than 20%
- Operating temperature: 0° to 120°F (-18°C to 49°C)

### LIGHT SOURCE

- Edge-lit technology uses a reflective light guide panel that disperses light through a diffused lens making it a practical and economical solution with high performance
- Low glare optic provides smooth diffused light
- Light engine's available in 3000K, 4000K, 5000K and 6500K
- High efficacy up to 100LPW
- Superior color rendering index, more than 80+

### PRODUCT IMAGE



### APPLICATIONS

- Residential, Hospitality, Retail, Office

### WARRANTY

- 3-Year limited warranty. Please refer [www.highlineled.com/](http://www.highlineled.com/) for complete warranty terms and conditions

### LISTINGS

- UL Listed Control Gear
- Damp Location Rated

## ORDERING INFORMATION

EXAMPLE ORDERING NUMBER : SFAPL-RD-10-ND-120-15-30-80-WH

--	--	--	--	--	--	--	--	--

Family	Shape	Size	Dimming	Input	Power/Lumens	CCT	CRI	Finish
SFAPL	RD - Round	10 - 10.62"	D - Dimming ND - Non-Dimming	120 - 120V 277 - 277V UNV - Universal	15 - 15W, 1500LM 22 - 22W, 2200LM 30 - 30W, 3000LM	30 - 3000K 40 - 4000K 50 - 5000K 65 - 6500K	80 - 80 CRI 90 - 90 CRI	SN - Satin Nickel
	SQ - Square	10 - 10.62"x10.62"			15 - 15W, 1500LM 22 - 22W, 2200LM 30 - 30W, 3000LM			

RoHS  
Compliant



Job Name:

Catalog Number:

Type:

# SFPL SERIES | SURFACE PANEL LIGHTS

## DIMENSIONS

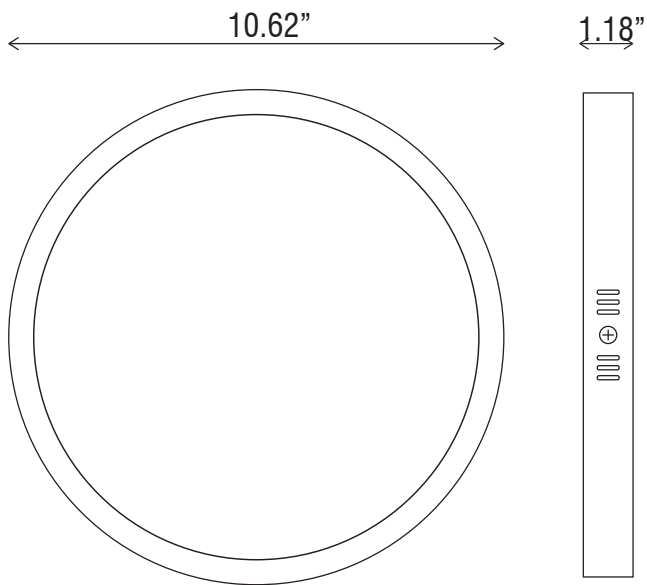
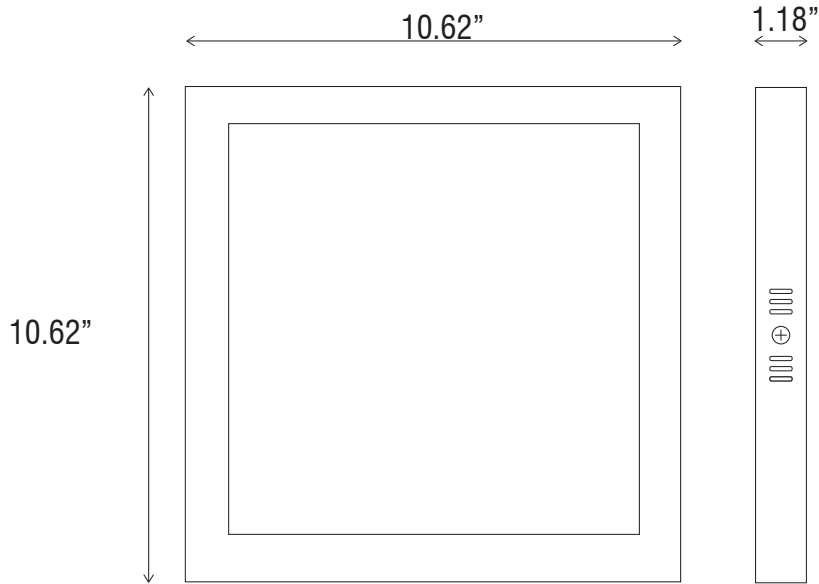

\*DUE TO THE CHANGES OF CONSTANT IMPROVEMENT IN LED TECHNOLOGY, ALL DETAILS ARE SUBJECT TO CHANGE WITHOUT NOTICE. CONSULT FACTORY FOR UP TO DATE INFORMATION.