



Job Name:

Catalog Number:

Type:

## ELD SERIES | EMERGENCY LED DRIVER

### FEATURES

- Listed for field installation UL924 and CSA C22.2 NO.141
- Selectable emergency power 8W, 12W, 15W
- Universal input 100-277VAC at 50/60Hz
- Constant output power (Auto-sensing output within each range)
- Output LVLE Compliant, RoHS Compliant
- Battery protections: Over voltage application, low voltage protection, over temperature protection, short circuit protection

### SPECIFICATIONS

- Input:** 100-277VAC at 50/60Hz
- AC Input Current:** 100mA Max.
- AC Input Power Rating:** 5.5W Max.
- Output Current and Voltage:** 320-600mA, 25V-48V
- Output Power:** 15W Max.
- Illumination Time:** >90 Minutes
- Test Switch/Charging Indicator Light:** Low voltage, illuminated test switch
- Battery:** High-Temperature, maintenance-free Ni-MH battery (5-Years Life Expectancy)
- Battery Charging Current:** 250mA
- Recharge Time:** >24 Hours
- Temperature Rating (Ambient):** 0°C to +50°C (32°F to 122°F)

### DIAL SWITCH CODE SELECTION

EMERGENCY POWER			
Power	Voltage	1	2
15W	25-48VDC	-	-
12W		-	ON
8W		ON	-

### NOTES

- When the dial switch code 1 and 2 turn off, the emergency power is 15W, 1 turn off and 2 turn on, the emergency power is 12W, 1 turn on and 2 turn off, the emergency power is 8W.

### WARRANTY

- 5-year limited warranty. Complete warranty terms located at: [www.highlineled.com](http://www.highlineled.com)

### LISTINGS

- UL Listed for field installation UL924 and CSA C22.2 NO. 141



RoHS Compliant



### PRODUCT IMAGE



### WIRING DIAGRAM

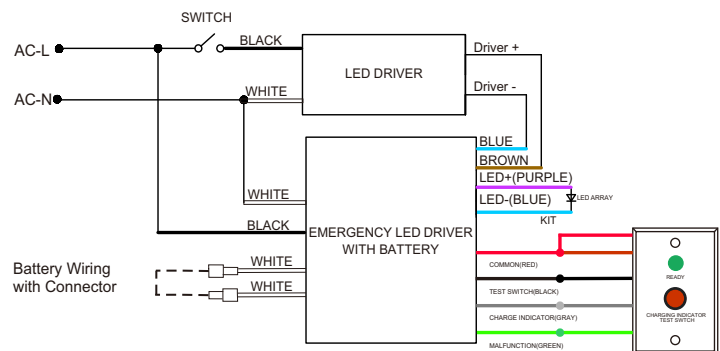

- DO NOT MATE CONNECTOR UNTIL INSTALLATION IS COMPLETE AND AC POWER IS SUPPLIED.
- TEST ACCESSORY LEADS-OBSERVE PROPER POLARITY WIRING

### DIMENSIONS

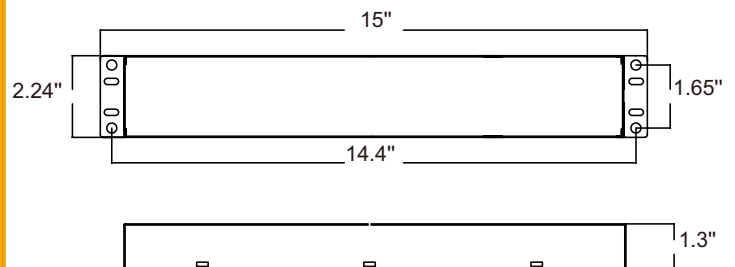



## ELD SERIES | EMERGENCY LED DRIVER

### IMPORTANT SAFEGAURDS

- When using electrical equipment, basic safety precautions should always be followed including the following:

### READ AND FOLLOW ALL SAFETY INSTRUCTIONS

- Risk of fire or electric shock. Luminaire wiring and electrical parts may be damaged when drilling for installation of LED Emergency Backup. Check for enclosed wiring and components.
- Risk of fire or electric shock. This LED Emergency Backup installation requires knowledge of luminaire electrical systems. If not qualified, do not attempt installation. Contact a qualified electrician.
- Before installing, make certain the AC power to the fixture is off.
- The electrical rating of this product is 100-277Vac. Installer must confirm that there is 100-277Vac to the fixture before installation.
- To prevent electrical shock only mate unit connector after installation is complete and before the AC power to the fixture is back on.
- Do not use outdoors.
- This LED Emergency Backup unit requires an un-switched AC power source of 100-277Vac, 50/60Hz. The AC driver must be on the same branch circuit as the LED Emergency Backup unit.
- Do not let power supply cords touch hot surfaces.
- Do not mount near gas or electric heaters.
- Do not connect battery pack connector until all other wiring is complete and AC power is on.
- Equipment should be mounted in locations and at heights where it is not be subjected to tampering by unauthorized personnel.
- The use of accessory equipment is not recommended by the manufacturer and may cause an unsafe condition.
- Do not use this equipment for other than its intended use.
- Use with grounded, UL Listed, dry or damp location rated fixtures.

### SAVE THESE INSTRUCTIONS

### APPLICATIONS

- The BLD-AM15D-480600 emergency driver can be used with most LED loads that have a rated voltage of 25-48Vdc.
- These emergency driver have been evaluated to and found compliant to UL 924.
- The emergency pack assembly is accepted as a component of a luminaire where the suitability of the combination shall be determined by UL or Authorities.
- The as-installed performance of the system must meet or exceed all Federal, State, and Local code requirements.

### OPERATION

- AC Operation:** AC power is present. The AC driver operates the LED load as designed. AC LED driver that has an output current not to exceed 4.0 A. The emergency pack is charging in a standby mode. The charging indicator will be lit, showing that the battery is charging.
- Emergency Operation:** When the AC power goes out, the emergency pack detects the power outage and automatically switches to the emergency mode. The charging indicator will be off. The LED load is illuminated, for a minimum of 90 minutes. When AC power is restored, the emergency pack switches back to Normal Mode and starts re-charging.
- Malfunction Mode:** When the emergency driver internal circuit without fault and battery normal, The green LED will be lit, When battery disconnected and the emergency driver circuit is faulty, the green LED is off.